



Technical Sheet and Installation Guide
Hebel® Masonry
Autoclaved Aerated Concrete

 German
 Technology

 **hebel®**



About Hebel®

Hebel® is a registered trademark of Xella Group, a German technology. In the USA, we are now part of Bexel International Group, manufacturing Autoclaved Aerated Concrete products, following the highest quality standards of the industry. Hebel® offers the most efficient solution in construction systems, more than 80 years in the market support us. We have been present in America since 1994.

Hebel® is distinguished by being a high-quality, innovative option that combines various properties in a single material. The benefits are reflected from the construction phase, it is up to 5 times lighter than traditional concrete, and has a significant impact on reducing construction time, as well as generating great savings in steel, concrete and labor.

We promote sustainability with high energy efficiency in all types of buildings.

Our systems provide high thermal performance, maximum fire resistance, acoustic insulation and resistance to humidity.

Hebel® is committed to providing to the United States with environmentally responsible building solutions that conserve material and energy usage. We are members of the Green Building Council.

Hebel® Autoclaved Aerated Concrete offers to contractors with strong, easy-to-install blocks and reinforced panels that are one-third the weight of traditional concrete and replace traditional multi-step construction processes.

Our building systems offer low insurance and maintenance cost to the building owner. A wide range of projects can benefit from Hebel® blocks and reinforced panels, including those in the commercial, educational, hospitality, industrial, institutional, governmental and residential segments.

Due to the AAC qualities, Hebel® has national and international recognized certifications, their manufacturing process is carefully monitored at all

stages, in order to guarantee the best quality for our customers.

Its properties take any project to a higher category, managing to build a better quality life, comfort and savings for a lifetime. At Hebel® we care to offer a full experience with a 360 service for each project specification.

The Hebel® Plant is located in Nuevo León, México and its USA offices are located in San Antonio, TX., from where we serve the USA market.

Aerated Concrete Hebel® : Unique properties in a single material.

Benefits



Thermal Insulation

Buildings constructed of HEBEL AAC provide substantial energy savings in both hot and cold climates. The unique closed cellular structure and the thermal mass contribute to a high R-value and air-tightness which reduce heating and cooling costs and improve indoor air quality. **Buildings have seen savings on air conditioning up to 35% by using HEBEL AAC.**



Structural Performance

Resists wind pressures. High impact resistance.



Fire Resistant

We are **certified** by Underwriters Laboratories (UL) with the **maximum fire-rating classification**. Our systems **withstand fire exposure up to 4 hours**, maintaining their structural integrity and **DO NOT emit toxic fumes** even under intense heat.



Acoustic Insulation

Provides exceptional acoustic insulation. Its porous structure and high surface mass, coupled with its ability to dampen mechanical vibration energy, **greatly reduces sound transmission from exterior - interior and room-to-room.**



Resistance to humidity

Protects against moisture. It allows the passage of water vapor, reducing condensation.



Green Building

- Recyclable, inert & non-toxic
- Energy saving
- Durable
- LEED credits



Easy treatment

Can be **easily cut, drilled and grooved** with manual or power tools.



Lightweight

Its lightweight nature allows a **faster and more efficient construction.**



Pest resistance

Not a food source for termites or vermin and no cavity construction. **Eliminates the chance of harbouring pests.**

Physical Properties

The physical properties of HEBEL Autoclaved Aerated Concrete are unique to any other building material. Properties such as thermal insulation and fire resistance cannot be met by another product alone.

- Speed of Construction
- Thermal Insulation & Energy Savings
- Superior Fire Resistance
- Sustainable
- Relatively high strength for a low density
- Workability
- Acoustic Performance
- Precision

This product meets Standards and Evaluation issued by:



ACI
530-13
ACI
523.4-R09



ASTM
C 1693-11
ASTM
C 1660-09



Index

Introduction to Hebel® Masonry Autoclaved Aerated Concrete

Description	3
Advantages	3

1 Technical Sheet

1.1 Hebel® Masonry	5
--------------------------	---

2 Design Considerations

2.1 General Considerations	6
----------------------------------	---

3 Installation Guide

3.1 Check Foundation	7
3.2 Receiving and Distribution of Hebel® Wall Units	7
3.3 Installation Requirements	7
3.4 Mixing Hebel® Thin Bed Mortar	8
3.5 Installing Hebel® Cored Block for Pilasters in First Course	8
3.6 Hebel® Masonry Installation	8
3.7 Utilities Installation After the Walls are Built	11

4 Renders and Finishes

4.1 Products	12
--------------------	----

5 Fasteners

Fasteners	12
-----------------	----



Hebel® Masonry Autoclaved Aerated Concrete



Uses and applications

Hebel® Masonry are used to build reinforced load-bearing and nonload-bearing exterior and interior walls for residential and commercial, industrial and fire and shaft walls, commercial and industrial.

Hebel® AAC meets the diverse demands better than any other material due to the numerous advantages of its physical, mechanical and energy efficiency properties.

Construction Advantages

- Solid walls.
- Energy savings 35%.
- Eliminates thermal bridges.
- Faster construction.
- High structural performance.

Application:

- Commercial
- Residential
- Industrial

Certifications:

NOM, ONNCCE, ASTM, UL, IAPMO, ACI, USGBC, TDI.

More benefits of Hebel® Masonry

- Savings in construction time and workforce.
- Fire resistance
- Acoustic performance
- Humidity resistance.
- Minimum waste
- Friendly to the environment.
- Sustainable.



Hebel® Masonry
Autoclaved Aerated Concrete

German
Technology



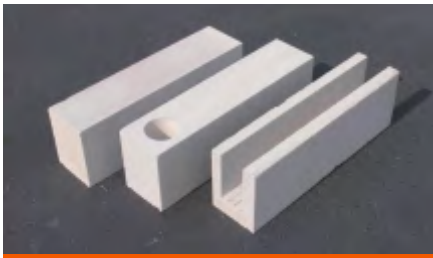

Fig. 1.

1 Technical Sheet

1.1 Hebel® Masonry

General Features

Hebel® Autoclaved Aerated Concrete (AAC) Masonry (Solid Block, Cored Block and U-Block) are lightweight, fire resistant, fast and easy to install and provides lifelong superior thermal insulation. Hebel® AAC Masonry Blocks are produced in two different strength classes: AAC4 and AAC6.

Uses

Hebel® Masonry are used to build reinforced load-bearing and nonload-bearing exterior and interior walls for residential and multi-family housing, hotels, hospitals, office buildings, fire and shaft walls, commercial and industrial buildings. Hebel® AAC meets the diverse demands better than any other material due to the numerous advantages of its physical, mechanical and energy efficiency properties.

Dimensions			
Block	Solid Block	Cored Block	U-Block
Length: ⁽¹⁾	24 in		
Height: ⁽¹⁾⁽²⁾	8 (7-7/8) in		
Thickness: ⁽¹⁾⁽³⁾	4, 5, 6, 7, 8, 10 and 12 in	5, 6, 7, 8, 10 and 12 in	
Strength Class:	AAC-4 and AAC-6		

⁽¹⁾Tolerance ± 1/8", ⁽²⁾ [Exact dimension], ⁽³⁾ Nominal Thickness. Product manufactured according to ASTM C1693-11

Characteristic	Unit	AAC-4 Class	AAC-6 Class
Compressive Strength (f' aac)	psi	580	870
Nominal Density	pcf	31	37
Design Weight	pcf	37	45
Drying Shrinkage	%	0.02	0.02
Thermal Expansion Coefficient	1/°F	4.4 x 10 ⁻⁶	4.4 x 10 ⁻⁶
Modulus of Elasticity	psi	295,000	377,000
Modulus of Rupture (MOR)	psi	115	142
Allowable Bearing Stress	psi	348	523

Table 1: Physical and design properties.

Hebel® Block Pallet									
Thickness* in (in)	Solid Block			Cored Block			U-Block		
	pce	ft ²	ft ³	pce	ft ²	ft ³	pce	ft ²	ft ³
4 (3.937)	180	236.3	77.5	-	-	-	-	-	-
5 (4.921)	144	189.0	77.5	144	189.0	77.5	108	141.8	58.2
6 (5.906)	120	157.5	77.5	120	157.5	77.5	96	126.1	62.1
7 (6.890)	96	126.0	72.3	96	126.0	72.3	72	94.6	54.3
8 (7.874)	84	110.3	72.3	84	110.3	72.3	72	94.6	62.1
10 (9.843)	72	94.5	77.5	72	94.5	77.5	48	63.0	51.7
12 (11.811)	60	78.8	77.5	60	78.8	77.5	48	63.0	62.1

*Nominal Thickness (Exact Thickness), Height= 8 (7.875)", Length= 24"

Table 2: Hebel® Block packaging.

Shipping						
Equipment	Capacity	Dimensions		Platform		
		Platform (ft)		Single		
	lb (Ton)	Length	Wide	Pallet ⁽²⁾	ft ³	
Platform (Flat Bed) Trailer ⁽¹⁾	44,100 (20)	40	8	14	1085	

⁽¹⁾FOB Shippings (origin or destination), ⁽²⁾ e.g. Solid Blocks 8" (AAC-4)

Table 3: Trailer load capacity.



Hebel® Cored Block					
Thickness*	DiamØ	d ₁	d ₂	d ₃	Volume
(in)	(in)	(in)	(in)	(in)	ft ³ /yd
5	2.75	2.46	1.08	20.17	0.1243
6	3.54	2.94	1.17	19.29	0.2054
7	3.54	3.44	1.67	18.79	0.2054
8	4.33	3.93	1.76	17.91	0.3069
10	4.33	4.91	2.74	16.93	0.3069
12	4.33	5.90	3.73	15.94	0.3069

Table 4: Hebel® Cored Block dimensions.

Hebel® U-Block					
Thickness*	a	b	c	d	Volume
(in)	(in)	(in)	(in)	(in)	ft ³ /yd
5	1.5	2.0	1.5	2.125	0.2448
6	1.5	3.0	1.5	2.125	0.3672
7	1.75	3.50	1.75	2.125	0.4284
8	2.0	4.0	2.0	2.125	0.4896
10	2.0	6.0	2.0	2.125	0.7344
12	2.0	8.0	2.0	2.125	0.9792

Table 5: Hebel® U-Block dimensions.

Thermal Conductivity		
Thermal Conductivity	Class	
Steady-State	AAC-4	AAC-6
	0.9124 BTU-in/ft ² -h-°F	0.9811 BTU-in/ft ² -h-°F

Unit: BTU = british thermal unit , in = inches, ft = pie, h = hour, °F = grados fahrenheit

Table 6: Hebel® Block thermal conductivity.

Acoustic Performance		
Assembly Type	STC	Report No.
Hebel® 6" Wall AAC-4 Unfinished	44	AS-TL958AX
Hebel® 8" Wall AAC-6 Unfinished	50	AS-TL1026AX
Hebel® 10" Wall AAC-4 Unfinished	50	AS-TL978AX
Hebel® Double 5" Wall AAC-6 (airspace 4", no fill) Unfinished	60	AS-TL962AX

Note: Testing performed at Acoustic Systems, Inc. 415 East, Elmo Rd., Austin, TX in accordance with ASTM E90 "Standard Method for Laboratory Measurement of Airborne Sound Transmission Loss of Building Partitions". STC = Sound Transmission Class.

Table 7: Hebel® Block acoustic performance.

Fire Performance		
Wall Components Class AAC-4 and AAC-6	Fire Rating (Hours)	UL Design Number
Non-load bearing Hebel® Block Wall 4" min. (Solid)	4	U919
Load bearing Hebel® Block Wall 6" min. (Solid)	4	U919
Load or non-load bearing Hebel® Cored Block Wall 8" min.	4	U919
Fire protection for existing column (4" Hebel® Block)	4	X901

Note: Testing performed at Underwriters Laboratories, Inc., Northbrook, IL under ASTM E119 (UL/ANSI 263) "Fire Tests of Building Construction and Materials".

Table 8: Hebel® Block fire rating.

2 Design Considerations.

2.1 General Considerations.

- Hebel® Masonry (block units) can be used to build load-bearing or nonload-bearing walls. Masonry walls built of Hebel® AAC Masonry must be designed following guidelines established by IBC 2016 Chapter 21, and Chapter 11 of the Building Code Requirements for Masonry Structures (ACI 530-13/ ASCE 5-13/TMS 402-13).
- Hebel® Cored Block units (Cored Blocks) can be used to build pilasters designed according to Local Building Codes.

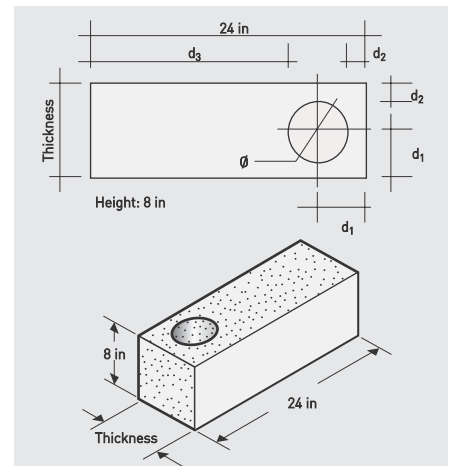

Fig. 2: Hebel® Cored Block for vertical reinforcement.

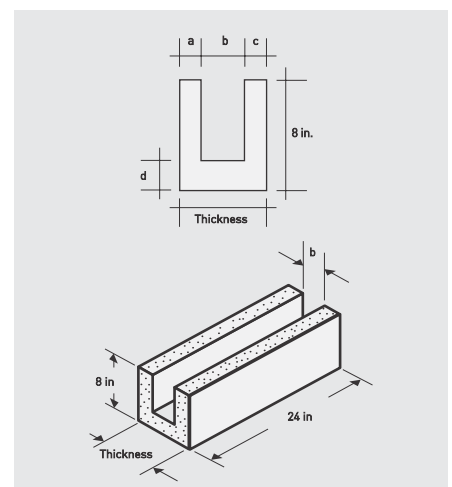

Fig. 3: Hebel® U-Block for horizontal reinforcement.

- Hebel® U-Block units can be used to build bond beams and headers lintels (to span door and Windows openings).
- Special considerations for construction located on seismic areas must be followed in accordance with section 2106 of the IBC Code.
- Control joints on Hebel® Masonry AAC reinforced walls must be placed at maximum 16 ft o.c. (see Fig. 6 and 20)

3 Installation Guide.

Before Installation Hebel® AAC Masonry

3.1 Check Foundation

Foundation must be designed according to Local Building Codes.

Masonry requires rebars for pilasters, vertical reinforcement (see Fig. 6). Rebar spacing must be according to Local Building Codes, IBC and ACI Codes. At opening locations (doors, Windows, etc), vertical rebar for pilaster must be placed on both sides (or less than 2 ft) of window and door openings (see Fig. 20).

Note A: Structural elements (steel, concrete) that provide Vertical support to AAC Masonry must be designed for a maximum deflection of $L/600$. L=span of support member.



Fig. 4: Hebel® Block pallets.



Fig. 6: Check foundation (pipes, drains, reinforcement, etc).

Before concrete is poured, check slab dimensions and reinforcement to comply with construction drawings. Ensure the pipes, drains and other penetrations through the slab have been installed properly. A brick ledge is recommended for the exterior walls (see Fig. 8).

Hebel® Masonry Components installations will be easier on a level slab.

3.2 Receiving and Distribution of Hebel® Wall Units

Carefully unload the Hebel® pallets using an all terrain forklift. Rubbing between pallets can cause damage to some pieces. Place pallets around the slab (above ground level) and close to work area (see Fig. 4 and 5).

3.3 Installation Requirements

The actual list of tools, equipment and other materials will depend on type of project and workforce.



Fig. 5: Forklift and flatbed trailer.

Tools:

- Hebel® Notched Trowel.
- Rubber Mallet (24 oz min).
- Brick Trowel.
- Masonry Level.
- Masonry Scrub Brush.
- Sanding Float.
- Hebel® Plastic Bucket.
- Spatula.
- Chalk-Line.
- Nylon Construction Line.
- Wooden Line Blocks.
- Tape Measure.

Equipment:

- ½" Power Drill.
- Stirrer for Power Drill.
- Hebel® Hand Saw.
- Hebel® Square.
- Hebel® Electric Band Saw (optional).
- Hebel® Chasing Tools.
- 4½" Angle Grinder.
- Safety Equipment (Hard hat, face-shield, goggles, dust mask, ear plugs, gloves, safety shoes, etc).

Other Materials:

- Hebel® Metal Strip Connectors.
- Fiberglass Mesh.
- Backer-rod & Caulking.
- Cement-Sand Mortar.
- Hebel® Thin Bed Mortar.
- Hebel® Repair Mortar.
- Hebel® Stucco.
- Hebel® Rustic Finish.
- Base-Coats, Textures, etc.
- Anchors & Hebel® Nails.

3.4 Mixing Hebel® Thin Bed Mortar

Hebel® Thin Bed Mortar is prepared in a plastic bucket, adding clean water (for half bag of mortar add approximately 1.1 gallons of water) and mix with a stirrer using a power drill. Remix before application.

The consistency should allow mortar to flow easily through a notched trowel, leaving the shape of the teeth in the mortar bed (see Fig. 15). Mortar workability time is 4 hours.



Fig. 7: Tools and equipment.

3.5 Installing Hebel® Cored Block for Pilasters in First Course

A simple way to build pilasters is by using Hebel® Cored Block units. They should fit over a rebar that is sticking up from the foundation, according to construction drawings. Optionally, if rebar is not embedded or misplaced, drill a hole into the slab, fill up the hole with epoxy adhesive and insert the rebar (see Fig. 8).

3.6 Hebel® Masonry Installation

a. Mark and Level the Slab

Once the foundation is ready, it will be necessary to mark (using a chalk line) the location of the walls, including door openings, in accordance with construction drawings. It is recommended to apply a water proofing barrier on the slab anywhere Hebel® Block Components will be installed (see Fig. 8).

Check around the reference wall lines marked on the slab to locate the highest point. At this point, add 1/2" (of cement-sand mortar bed) to 7 7/8" (of Hebel® Block height) to obtain the "top of leveling course".

It is recommended to set the string line level from the "top of leveling course point" to assure level of first course. The string should be stretched, hooking the line blocks properly. At the same time, the line should be checked using a line level.

b. Laying the First Course (Leveling Course)

Using a brush, clean block surface before installation. Lay the first course over a semi-dry cement-sand mortar leveling bed (minimum 1/2" thickness, maximum 2" thickness) see Fig. 10.

Corner blocks are laid first and the first course should be completed before second course installation. Once the corner blocks are placed, use a brush to clean next block surface before mortar application. For next blocks, apply Hebel® Thin Bed Mortar.

c. Cutting Block (Adjustments and Chases)

A Hebel® handsaw or a band saw can be used to cut the block to specific lengths (adjustment pieces) see Fig. 17.

If required, cut a chase for utilities not exceeding the maximum depth of chases (see Section 3.7 – Utilities Installations).

d. Placing Control Joints in First Course

The location of control joint should be specified in construction drawings. Hebel® joints are vertical joints taken

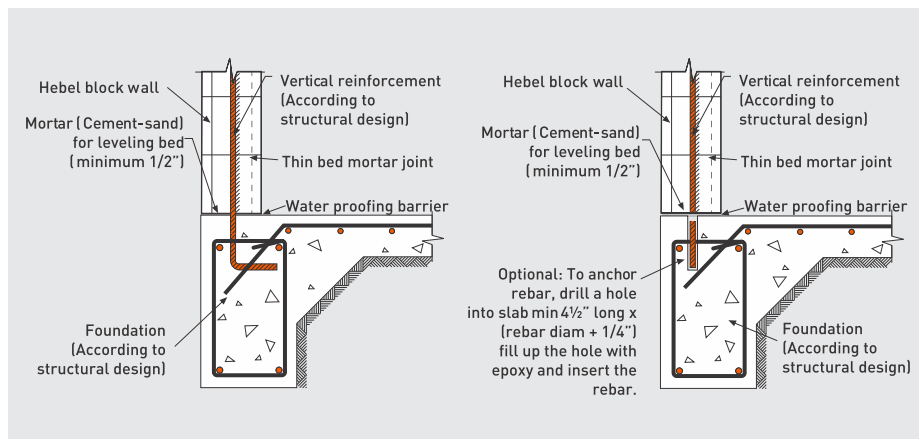

Fig. 8: Anchoring vertical reinforcement to foundation.



Fig. 9



Fig. 10

through the full wall thickness and from bottom (first course) to top. The width of the control joints should be $\frac{3}{8}$ " thick but no more than $\frac{1}{2}$ " thick. The maximum space between Hebel® joints should be 16 ft (see Fig. 14 and 20).

e. Laying the Subsequent Courses

For subsequent courses, use only Hebel® Thin Bed Mortar on all joints between Hebel® Blocks (see Fig. 15). Use a brush to clean the block surface before mortar application. After block installation, remove spilled mortar using a spatula. Minimum overlapping of vertical joints between layers should be 4 inches (see Fig. 20). It is recommended to check alignment and level after each unit installation to achieve a plumbed wall.

Hebel® metal strip ties should be placed every two courses at:

- Connection of secondary walls to main walls.
- Connection of CIP (cast in place column) into the wall.



Fig. 12

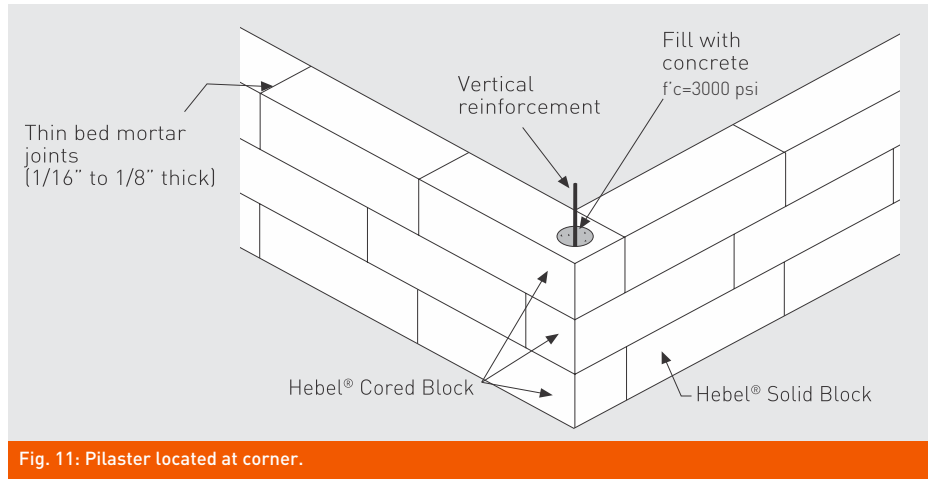

Fig. 11: Pilaster located at corner.

- Connection between cmu wall and AAC Wall.

f. Installing Hebel® Cored Block in Subsequent Layers for Pilasters

It's very important to check that Cored Block holes between courses are properly aligned when installing. Make certain that all rebars attaches to bars sticking up from the foundation comply with reinforcement specifications.

g. Control Joints in Subsequent Layers

Metal strips folded at midpoint (V-shaped) should be set at every 2 courses unless there are two pilasters (vertical reinforcement) on both sides of control joints (one pilaster each side) and less than 10" from control joint (see Fig. 20).

Once the wall is built, fill the gap using backer-rod and seal with caulking.

h. Fill Up Pilasters

Proceed to pour concrete (f'c= 3,000 psi min) into pilasters (cylinders) to complete wall Fig. 15 installation (see Fig. 18).

i. Building On-Site Lintels Using U-Blocks

When the use of Hebel® Lintels are not possible, and depending on the span and service load, lintels over door and windows openings can be made on site using Hebel® U-Block. Install temporary shore and prop supports before putting U-Block in place. Apply Hebel® Thin Bed Mortar to the vertical joints (see Fig. 16). Once the U-Blocks are set, place rebars according to construction drawings and with concrete (see Fig. 19 and 20).

"Please refer to our SDS for further information":

Caution: Use safety gear: Hard hat, dust mask and goggles to avoid excessive inhalation of dust and protection of the eyes when handling Hebel® Reinforced Masonry.



Fig. 13



Fig. 14



Fig. 15



Fig. 18



Fig. 21: Construction interior view.



Fig. 16

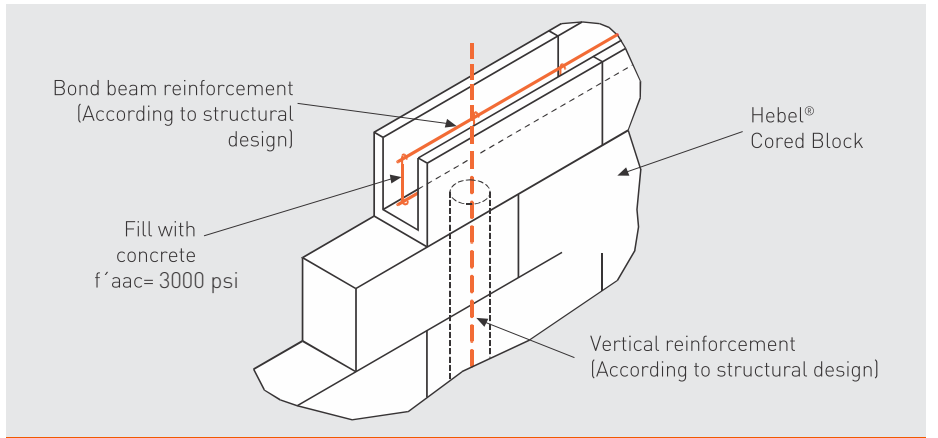

Fig. 19: Bond beam and pilaster connection.



Fig. 17

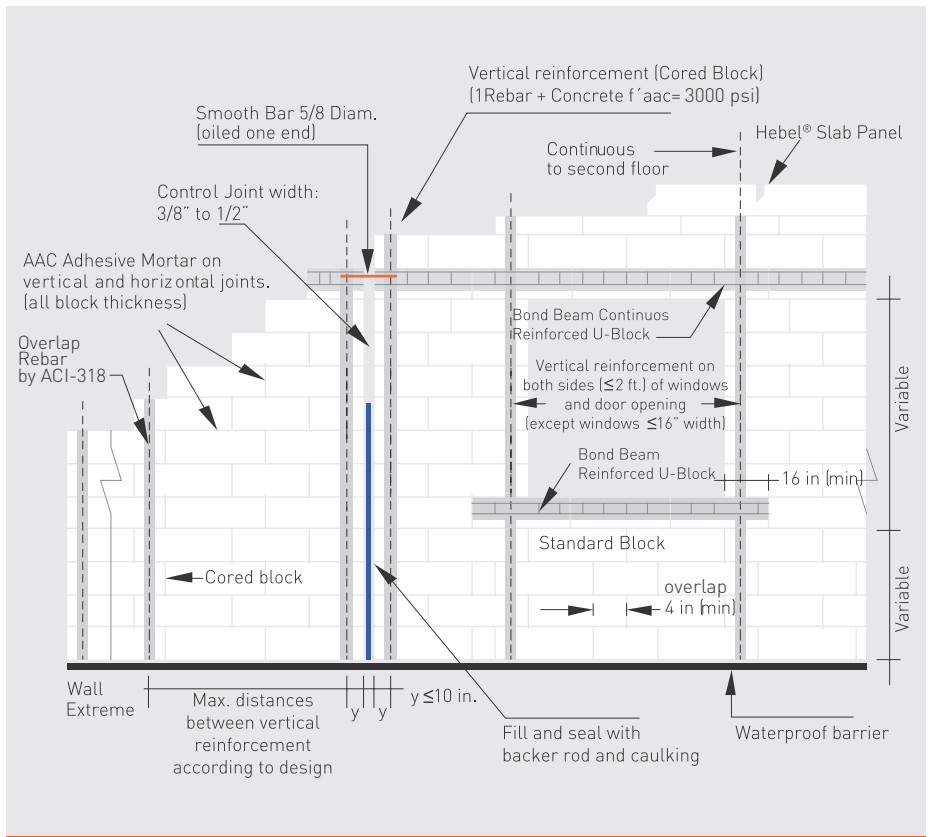

Fig. 20: Reinforced Masonry details and specifications.



Fig. 22: Three-story hotel construction.

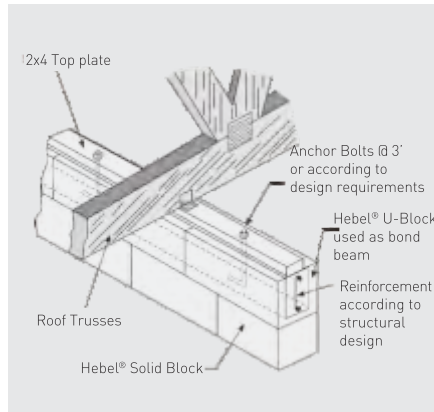

Fig. 23 A: Anchoring wood top plate to U-Block top bond beam.



Fig. 23 B: Anchoring wood top plate to U-Block top bond beam.

j. Installing U-Blocks to Build Bond Beams

Generally, bond beams are required through the top of the exterior and interior walls. Lay U-Block course, applying Hebel® Thin Bed Mortar on all joints (vertical and horizontal joints). At each pilaster location, drill a hole in the bottom side of the U-Block so the vertical bars can be attached into the bond beam, to comply with the reinforcement requirements.

Before pouring concrete, place rebars and anchor bolts according to construction drawings (see Fig. 23).



Fig. 24: Hebel® chasing tools.



Fig. 25: Water supply pipes.

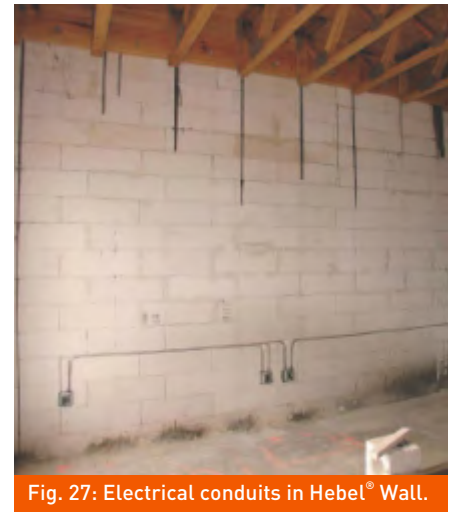

Fig. 27: Electrical conduits in Hebel® Wall.

3.7 Utilities Installation After the Walls are Built

For electrical conduits and piping installation, cut a chase using an electrical router or a chasing tool. To lodge electrical boxes, a power drill (drill bits) or router can be used (see Fig. 24 and 25).

When the required depth of chase is bigger than maximum depth recommended, use additional Hebel® Cored Blocks to lodge the pipes or interrupt wall continuity (see Fig. 26).

After installation, use Hebel® Repair/Patching Mortar or cement-sand mortar to fill the chases (see surface patching). During finishing step, place fiberglass mesh over the repair area according to recommendations (see Section 4 and Fig. 29).

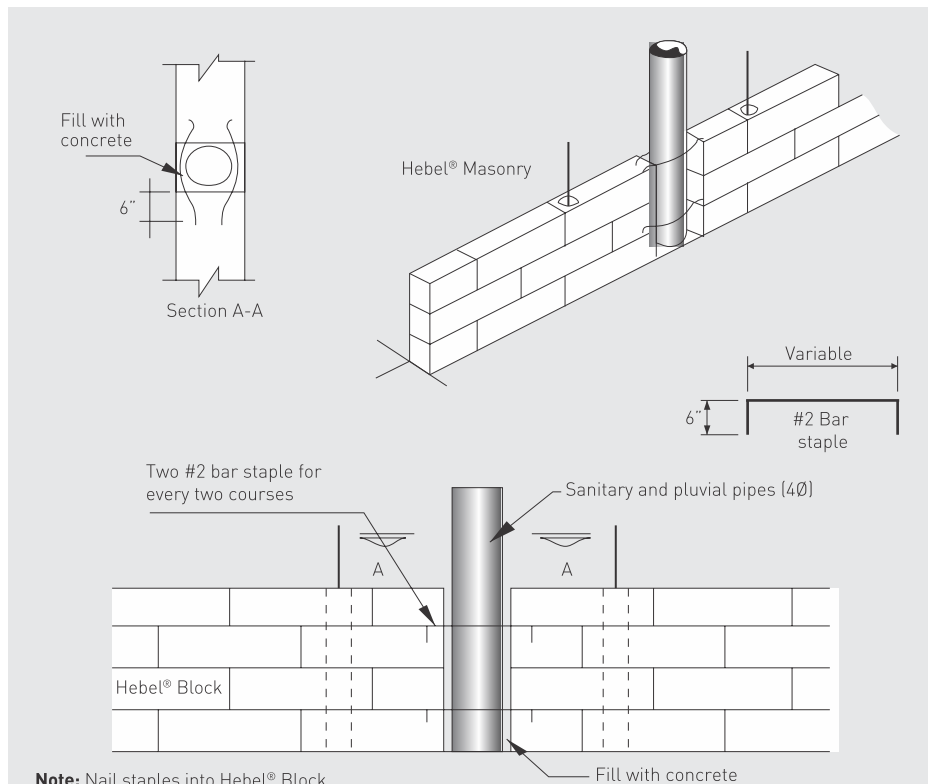

Note: Nail staples into Hebel® Block

Fig. 26: PVC drainage pipe detail.

4 Renders and Finishes

4.1 Products

Surface Patching

Rasp block joints and other areas where the AAC surface is out of plane. Surface must be clean, free of dirt, oil and any other matter. Loose or damaged material must be removed. Use Hebel® Thin Bed Mortar, Repair Mortar or cement-sand mortar to patch chips, breaks, chases for utilities and other imperfections on the wall surface. Products are applied using a spatula or trowel.

Before application, clean surface using a scrub brush. After application, a rubber float is commonly used to smooth the Wall Surface.

Fiberglass Mesh

Hebel® fiberglass mesh should be installed directly over one layer of render (embedded into first coat of plaster, e.g. stucco) in all control joints, around windows, doors, and through utility locations (see Fig. 29).

Finishes

Hebel® masonry walls can be finished with Hebel® stucco, acrylic texture coats, or a combination of stucco as a base-coat and acrylic texture as a finish coat, also laminated stones, ceramic or clay tiles, concrete pieces and ornamentals products.

Base-Coat

Apply a layer (1/4" thickness minimum) of stucco (cement-based or acrylic) or acrylic base-coats (Hebel®), according to manufacturer instructions. Reinforce base-coat using fiberglass mesh embedded partially (see Fig. 29) or in 100% of the surface area according to base-coat manufacturer.

Finish Coat

Apply ready-mix acrylic based products as decorative and protective finish coat (top-coat). Apply finish directly over the primed wall surface. Apply product by troweling with a stainless steel finishing trowel, depending on the finish specified.

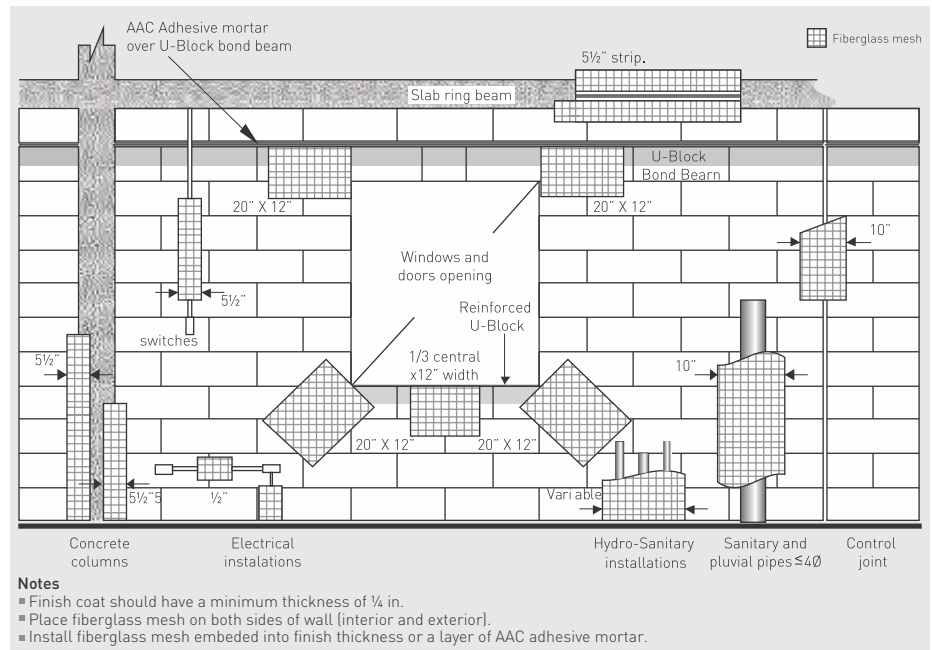

Fig. 29: Fiberglass mesh installation.

5 Fasteners

Fasteners

Anchors used with AAC shall be made of plastic or nylon. Wood, fiber, lead, metal or expansion anchors are not recommended. Use power drills to make holes for fasteners and masonry drill-bits recommended (diameter) on table 9 (drill-bit diameter may differ from recommended by fastener manufacturer; specifications have been adapted for AAC). Percussion drilling or inverting the rotation direction when drilling shall be avoided. The anchor shall penetrate tightly in the hole to avoid rotation when placing the screw. When using Fischer anchors, the external finish layer surrounding the hole should be removed to allow the anchor to fully penetrate into the AAC element.



Fig. 30: Minimum screw length.

Hebel® AAC Nail:

Hebel® galvanized AAC nails are designed specifically to provide a definitive anchorage in the AAC. Hebel® AAC nails are directly hammered-into the AAC element – no drilling is required.

Screws

Always use screws of the diameter recommended on table 9. Minimum length of screw is defined by the anchor length plus the thickness of the finish layer and the thickness of the element to be fixed.

Precautions

Load values (pull-out strength) shown in chart shall be used only as a reference guide; field testing is suggested according to project requirements. The load values (lb) shown in chart are for direct pull-out and a safety factor of 5 is included in them. Full penetration of screws into the anchor is assumed to obtain such load values.

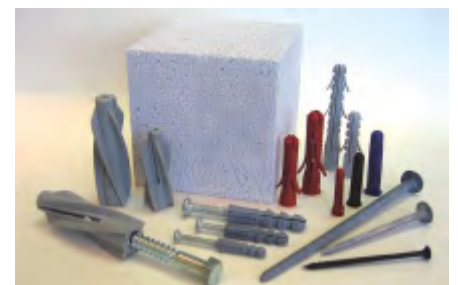

Fig. 31: Recommended nails & anchors.

Fasteners & Nails Autoclaved Aerated Concrete Technical Sheet		Anchor / Nail		Drill Bit for Masonry	Screw	Load Value* (pull-out strength)	
		Length	Ø Diam			AAC-4 Block	AAC-6 Panel
		in	in	Ø in	Ø in	Lb	Lb
	Hebel AAC Nails[®] Available at Litecrete, Inc.						
	Hebel AAC Nail 4 in.^[3] Min. Penetration: 3 in.	4"	1/4"	Fixed directly with hammer	Not Required	51	88
	Hebel AAC Nail 6 in.^[3] Min. Penetration: 5 in.	6"	5/16"				
		Dry Wall Screw Available at Construction Depots					
8 x 3"		3"	-	Not pre-drilling is required	Not Required	35	57
8 x 2 1/2"		2 1/2"	-				
	Universal Plastic Anchor Available at Construction Depots						
	Anchor TP 14 - 1/4"	1 1/8"	1/4"	1/4"	#10	22	26
	Anchor TP 56 - 5/16"	1 1/2"	5/16"	5/16"	#12	26	31
	Anchor TP 38 - 3/8"	2"	3/8"	5/16"	1/4"	44	62
	Note: For use in solid walls (Anclor [®] or similar).						
	THORSMAN[®] Available at Construction Depots						
	Anchor Red TP 2X^[4]	1 3/8"	1/4"	3/16"	#8	37	---
				1/4"	#10	---	42
	Anchor Brown TP 2B^[4]	1 1/2"	5/16"	1/4"	#10	49	62
	Anchor Blue TP 3^[4]	1 3/4"	3/8"	5/16"	#12	73	84
	TOX VLF[®] Available at www.demandproducts.com						
				No pre-drilling for AAC-4 Class			
	Anchor 6/70^[5]	2 3/4"	1/4"	1/4"	Anchor with screws included (pre-assembled)	66	---
	Anchor 8/80 - 8/135^[5]	3 1/8" +	5/16"	5/16"		102	---
Anchor 10/100 - 10/160^[5]	4" +	3/8"	3/8"	120		---	
	HILTI[®] Plastic Anchors Available at Hilti Shops and Construction Depots						
	Anchor HUD-1 (10x50)^[4]	2"	3/8"	3/8"	5/16"	71	90
	Anchor HUD-1 (12x60)^[4]	2 3/8"	1/2"	7/16"	3/8"	128	185
	More Products: www.us.hilti.com						
 GB14 S10H80R GB10	FISCHER[®] Available at Litecrete, Inc.						
	Anchor GB 10^[3]	2"	3/8"	3/8"	1/4"	126	---
				1/2"	1/4"	---	104
	Anchor GB 14^[3]	3"	5/8"	5/8"	3/8"	165	225
Anchor S10H80R^[3]	3 3/8"	3/8"	3/8"	5/16"	123	150	

Notes: ^[1]Anchors without screws, except TOX VLF anchors. ^[2]Drill bit diameter change between AAC-4 y AAC-6 classes.

Notes: ^[3] Available at Litecrete, Inc. ^[4] Available at Hilti Shops, Home Depot, Lowe's, etc. ^[5] Available at www.demandproducts.com ^[6] For AAC-6 (Block & Panel) use 1/4" drill bit. ^[7] For AAC-6 (Block & Panel) use 1/2"

drill bit. *Safety Factor [SF]=5. Use masonry drill bits. Anchors do not include screws (except TOX anchors).

IMPORTANT: Information has been adapted considering Autoclaved Aerated Concrete (AAC) material and may differ from original fastener manufacturer.

Table 9: Anchoring into Hebel[®] AAC Reinforced Masonry.

Contact us

Litecrete, Inc.

833 Isom Rd.
San Antonio, TX 78216

Phone (210) 402-3223 Fax
(210) 402-6390

1-877-41-HEBEL
hebel-usa@hebel-usa.com

www.hebel-usa.com



/Hebel Building Solutions